

**STEP 1**

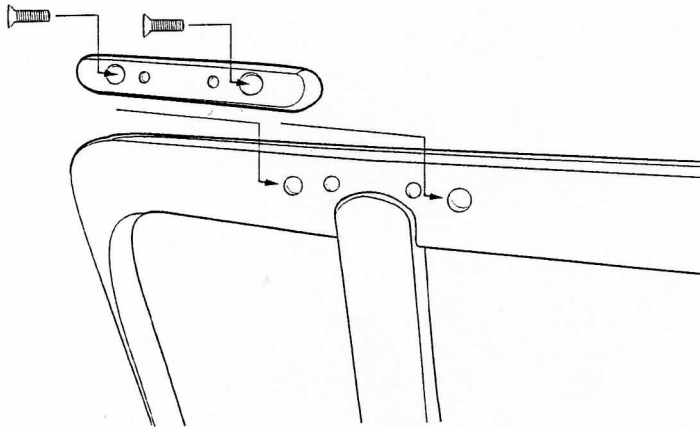

**STEP 2**

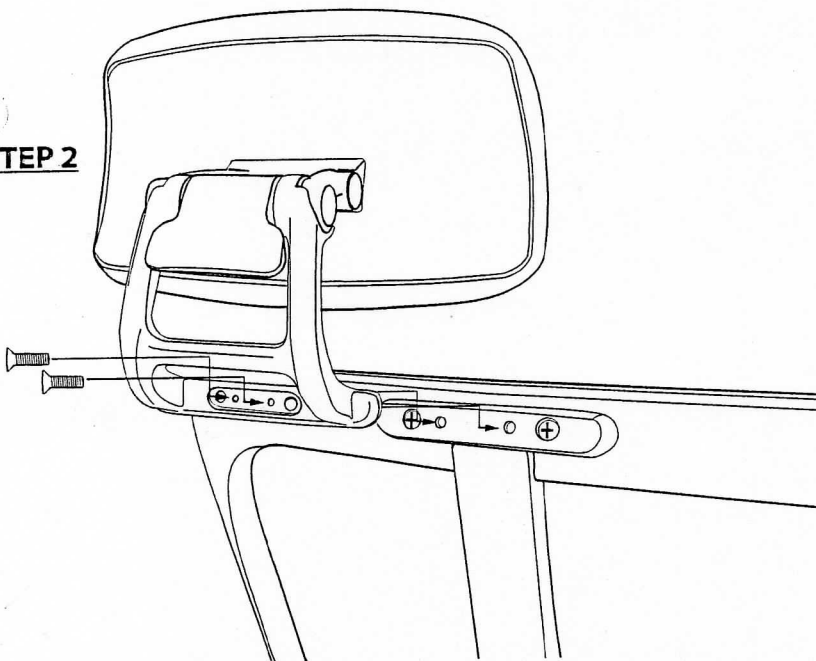

**STEP 3**

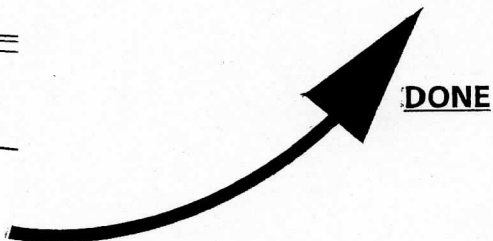
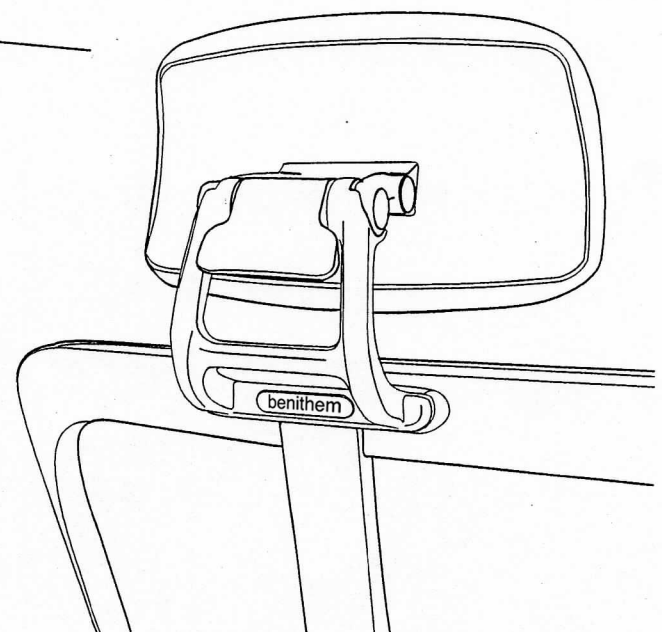
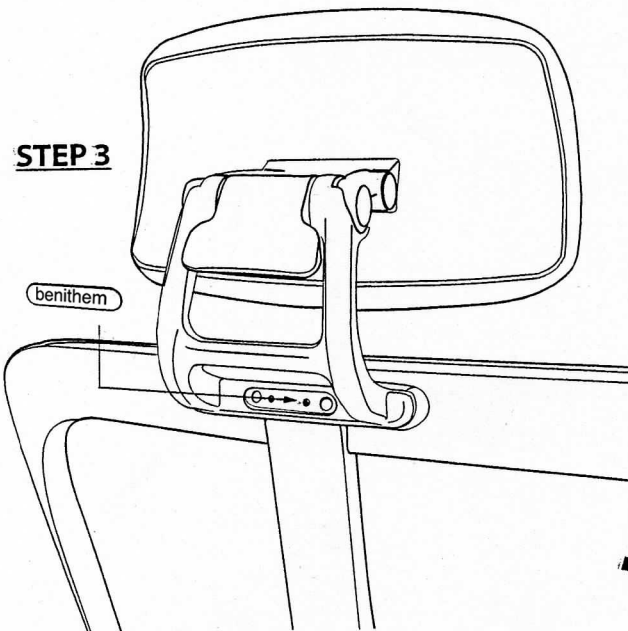

**DONE**

PARTS	STEP	DESCRIPTION OF HARDWARE	QTY/SET
Headrest Joiner	1	CSK head screw M5 0.8x20 (Nyllok)	2 PCS
Headrest Connector	2	M4x12 CSK Machine ( Provided by Supplier )	2 PCS
Capping	3	( None )	0 PC